

We are working on **"Control Theory"**

- **Develop control algorithms** using mathematical tools
- Analyze **dynamical behavior** of complex systems
- **Connect the gap** between theory and industrial problems

**"Nothing is more practical than a good theory."**

- Kurt Lewin

Mathematics

**Control Theory**

Engineering  
 (Electric, Mechanical,...)

**Professor Hyungbo Shim**



**Awards and Honors (selected)**

- 우수 강의 선정, 2006, 2007, 2008, 2011
- 대한전기학회 논문상, 2008
- 정보 및 제어 학술대회 우수 논문상, 2007, 2008, 2009
- 제 19회 과학기술우수논문상, 2009
- IEEE Senior Member, 2014
- 제 10회 신양공학학술상, 2014
- Outstanding Paper Award, Int. Conf. on Control, Automation and Systems, 2015
- 한국공학한림원 '미래 100대 기술과 주역' 선정, 2017

**On-line lectures @ <http://lecture.cdsl.kr>**

- Linear System Theory (선형시스템이론)
- Nonlinear System Theory (비선형시스템이론)
- Linear Algebra (선형대수)
- Convex Optimization (최적화기법)
- 최신제어기법
- 공학수학
- 제어공학개론
- Singular Perturbation, Sliding Mode Control

**연구실 출신 교수**

- 주성준, 호서대학교 디지털제어과
- 조남훈, 송실대학교 전기공학부
- 손영익, 명지대학교 전기공학과
- 천관호, 충남대학교 전기공학과
- 구현철, 건국대학교 전자공학과
- 여운승, 이화여자대학교 융합콘텐츠학과
- 백주훈, 광운대학교 로봇학부
- 장혁준, 국민대학교 전자공학부
- 서상보, 가천대 의용생체공학과
- 김홍근, 한국기술교육대학교 메카트로닉스공학부
- 좌동경, 아주대학교 전자공학과
- 김정수, 서울과학기술대학교

**About CDSL**

**Information**

- 석사 과정 4명, 박사 과정 10명 재학 중
- 자동화 시스템 연구소(ASRI, 133동)에 연구실 위치
- New York Univ, Purdue Univ, Technion 등 여러 해외 대학들에서 교수님 방문, 연구 교류, 세미나 개최, 학생들이 직접 연구 결과를 발표 및 논의
- 학생들의 연구 관심사에 따른 여러가지 주제의 스터디 그룹 존재

**Pre-requisites (recommended)**

- 제어공학개론, 최신제어기법 등 제어 시스템에 대한 기본 지식
- 선형대수, 해석학 등 시스템의 해석을 위한 도구
- MATLAB, C 등 기본적인 프로그래밍 능력

신입생을 위한 세미나(스터디)를 진행하여 연구를 위한 소양 함양  
 연 4회 연구실 설명회 개최 (<http://post.cdsl.kr/archives/15>)



# We are interested in ...

## Hybrid Systems

- Continuous + discrete behavior
- **CDSL's solution:**  
**"Glue discontinuity using geometric control theory"**
- ✓ Able to use widely-used techniques for continuous-time systems

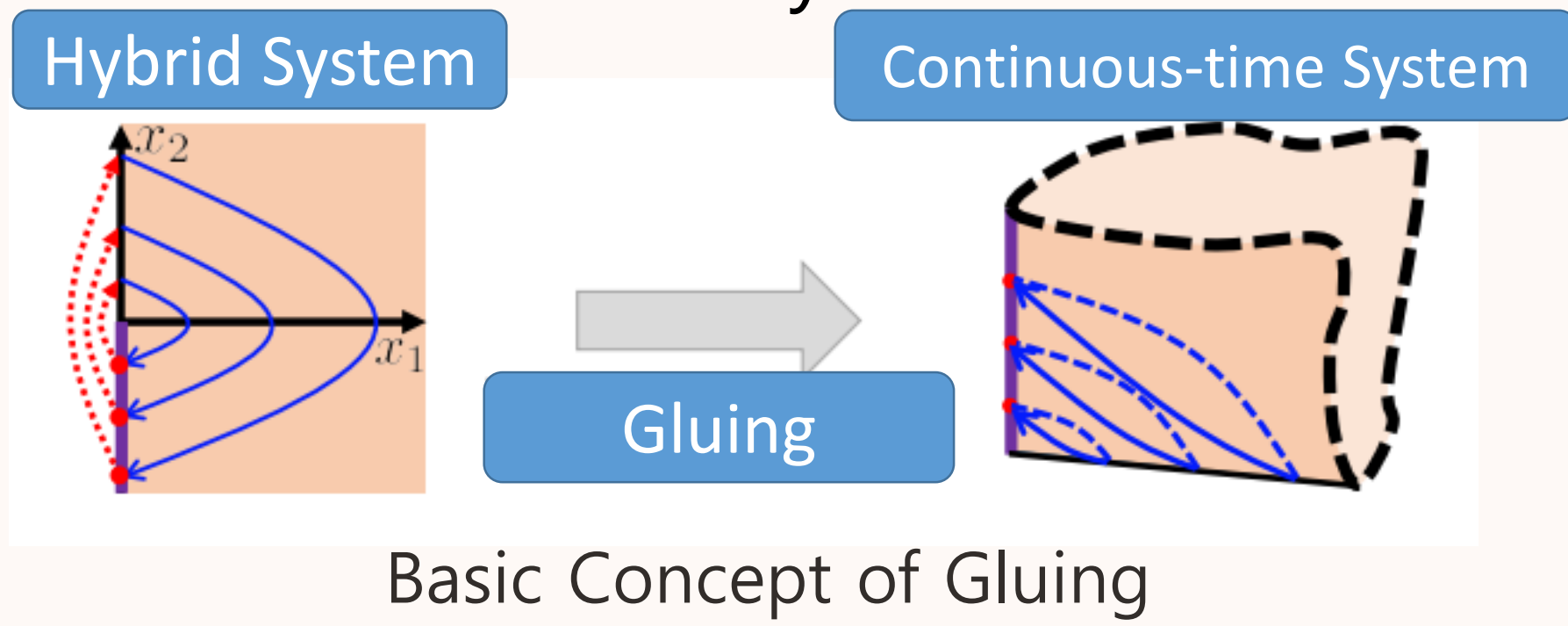

## Disturbance Observer

- How to design a robust controller that **compensates disturbance and uncertainty** at once
- **CDSL's solution:**  
**"Analyze its behavioral tendency under large bandwidth of Q-filter"**

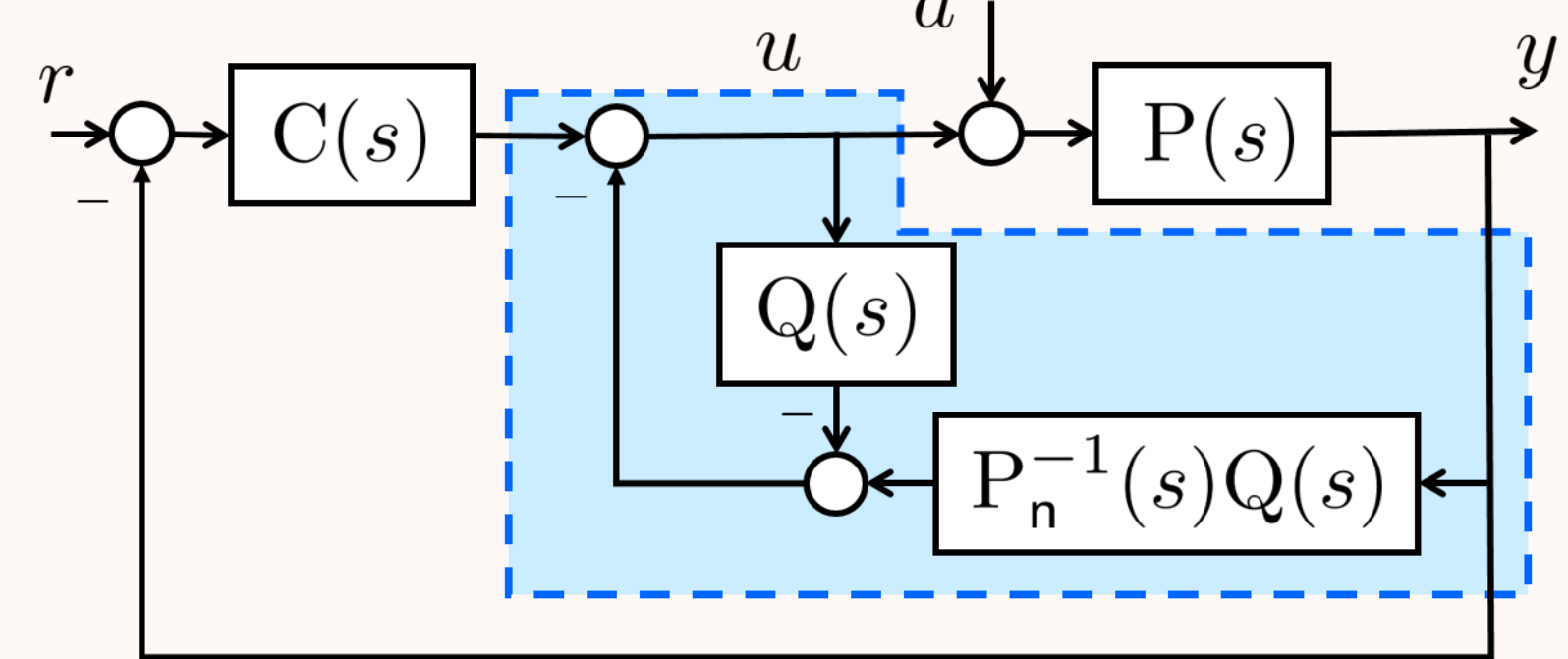

## Security of Cyber-Physical Systems

- Discover cyber-attack scenarios & develop its protection/detection methods
- **CDSL's solution:**  
**"Systematic & Control-theoretic Perspective"**
- ✓ **Sampling/Robust zero-dynamics attacks:** Stealthy attacks  
 ← Countermeasure: **Generalized hold**
- ✓ **Resilient state estimation:**  
 Identify sensor attack & estimate state only w/ trustworthy sensors

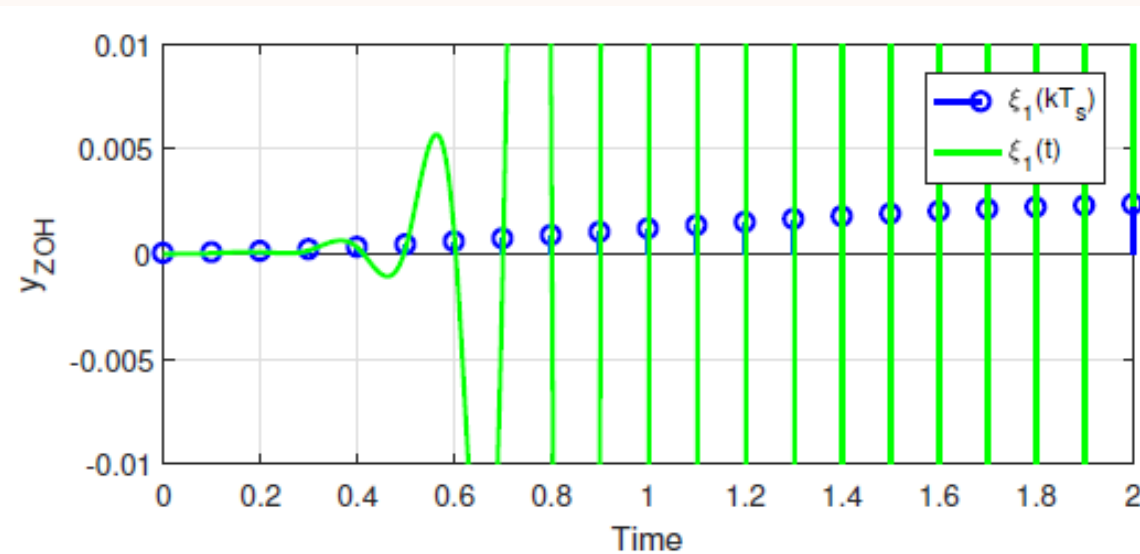

Effect of Zero Dynamics Attack

## Encrypted Control Systems

- How to improve **privacy and security** of control systems
- **CDSL's solution:**  
**"Employ homomorphic encryption scheme to linear dynamic control systems"**
- ✓ Design of controllers to have **integer state matrix**
- ✓ Approximation by **high order systems**
- ✓ Encrypted state estimation by Luenberger observers

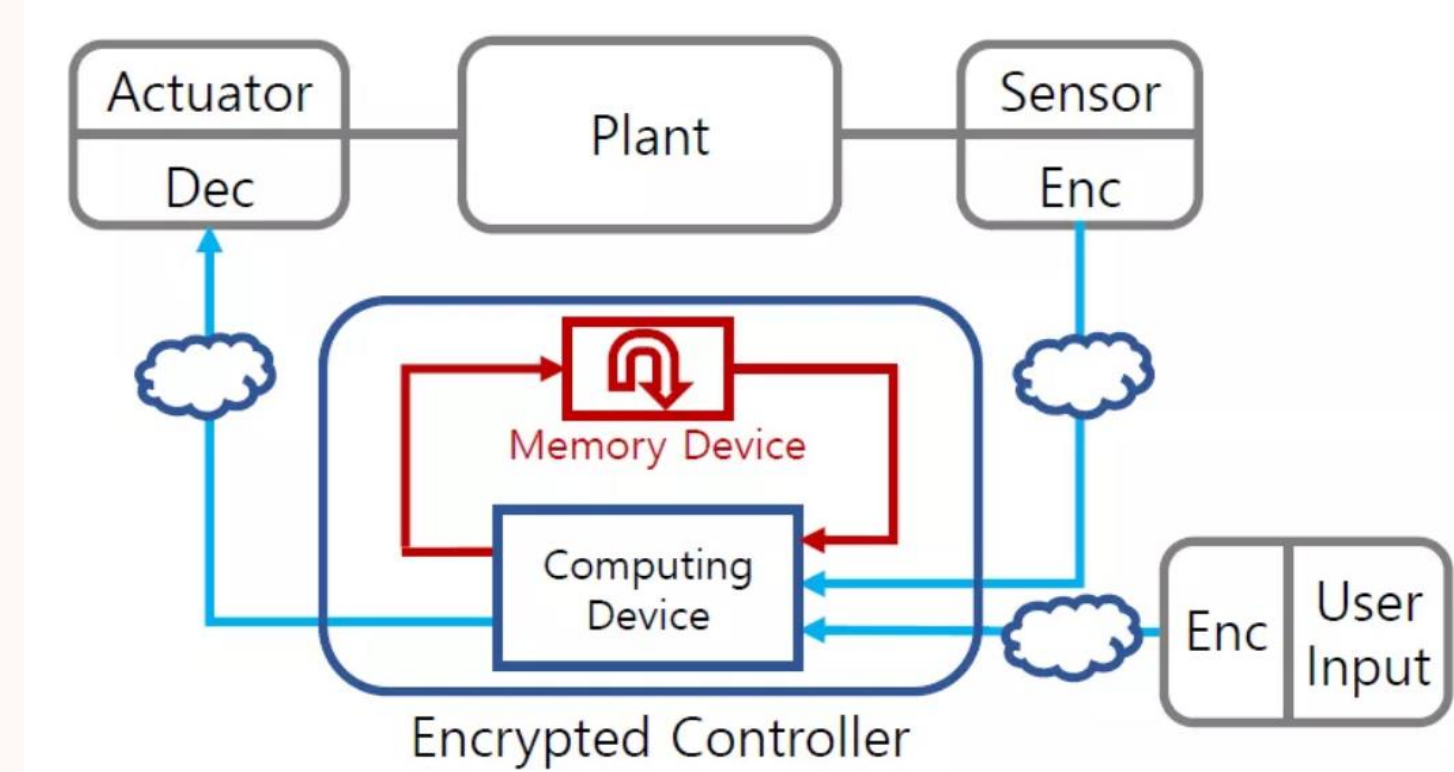

## Synchronization

- Study interactions of multiple agents to achieve a common goal
- Most studies focused on homogeneous agents, which is limited in real world applications
- **CDSL's solution:**  
**"Diffusive coupling with high gain results in blended dynamics"**
- ✓ Heterogeneous agents behave in similar manner

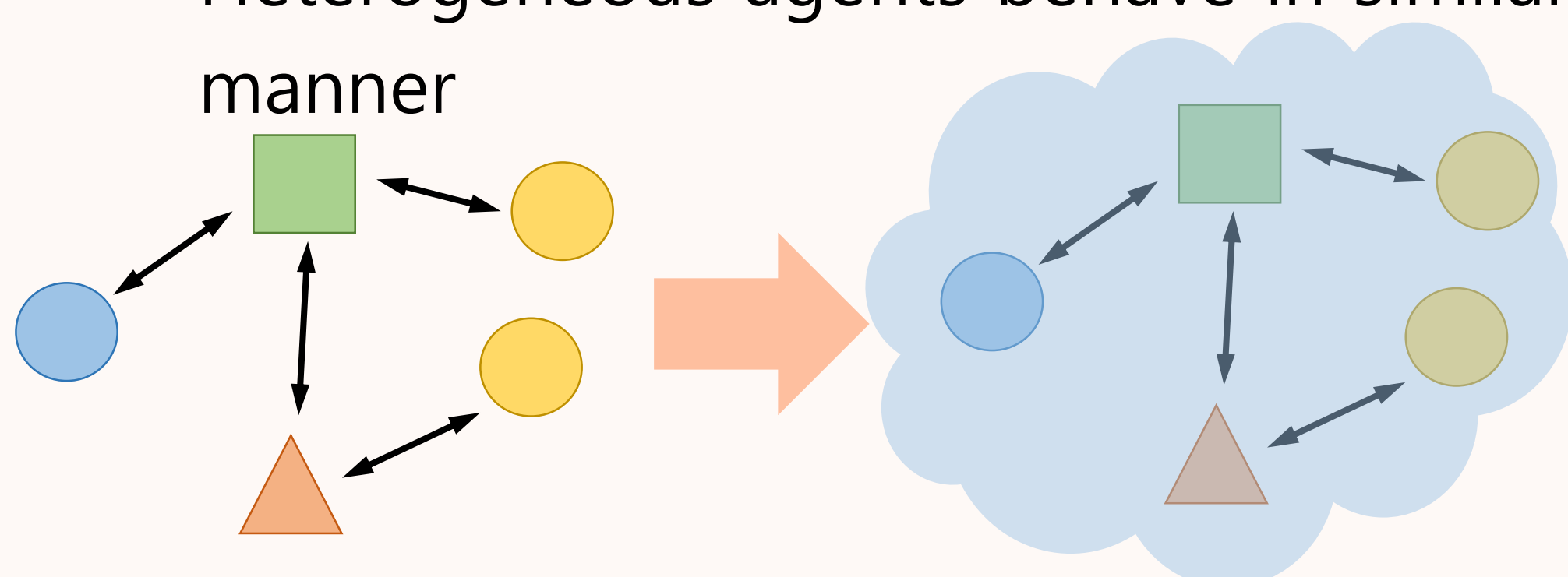

## Robust Learning-based Control

- Training with **real plant** (e.g. autonomous vehicle) is unsafe and expensive
- Using **simulation model**, discrepancy between simulation model and real plant could degrade performance
- **CDSL's solution:**  
**"Training with simulation model + uncertain real plant with DOB"**
- ✓ Recover sub-optimal performance

